

Diaphragm accumulator

hydrospeichertechnik.de/produkte/membranspeicher/

TECHNICAL DATA DIAPHRAGM ACCUMULATOR

STANDARD STEEL

STAINLESS STEEL

Design

The diaphragm accumulator consists of a welded pressure chamber on the oil side of which a connection tube is welded. The separation of the gas and the fluid is carried out by a diaphragm inserted in advance. There is a diaphragm button in the bottom of the diaphragm to prevent the diaphragm completely from destruction when the vessel is discharged. The diaphragm accumulator can be refilled by means of a gas filling screw or can be closed so that it is inseparable on the gas side. The fluid supply is available in different versions. Replacement of the diaphragm is not possible!

gas filling screw

pressure vessel

diaphragm

diaphragm button

fluid supply



Designation – Example of order

MS	2,0	-	210	/	1	/	N	/	A2	/	040	/	T	/	CE
1	2		3		4		5		6		7		8		9

1: Accumulator type

MS diaphragm accumulator

2: Nominal volume (Liter)

3: Max. permissible operating pressure

4: Design

1 gas can be refilled
2 gas cannot be refilled

5: Diaphragm material

N - NBR (zulässiger Temperaturbereich - 10°C bis + 80°C)
E - ECO (Hydrin) (zulässiger Temperaturbereich - 40°C bis + 80°C)
B - IIR (Butyl) (zulässiger Temperaturbereich - 15°C bis + 80°C)
V - FKM (Viton) (zulässiger Temperaturbereich - 20°C bis + 80°C)

6: Fluid supply

shape (see table)

7: Precharge pressure

p_0 (bar) at 20°C

8: Accumulator material

N - C-Stahl
R - Edelstahl (z. B. 1.4571)
T - Stahl für Temperaturen bis -40°C
R/N - Edelstahl / C-Stahl

9: Acceptance test - codes

CE Directive 2014/68/EU

Please for temperatures
about + 80°C consultation

Dimensions Diaphragm accumulator, welded construction

Diaphragm not exchangeable!

Design 1

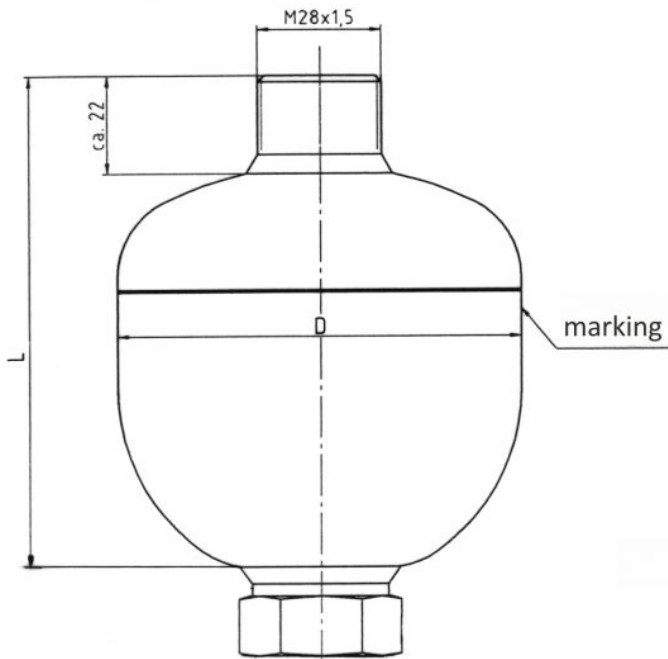

Design 2

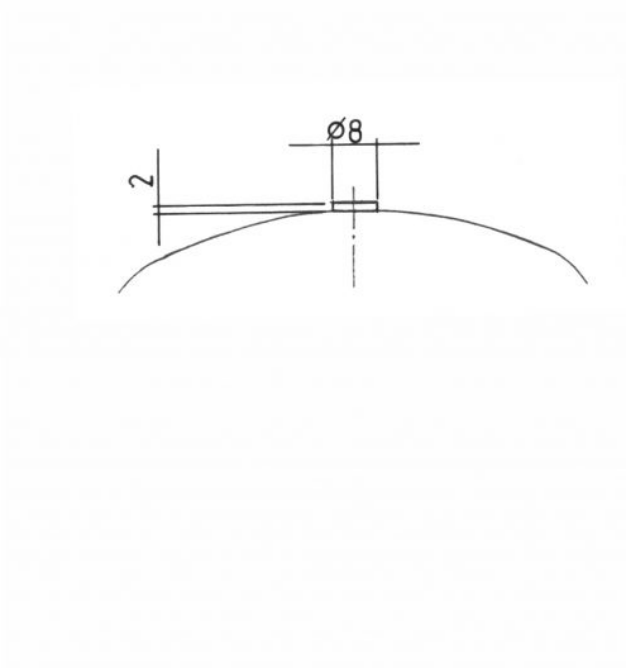

Fluid supplies

Shape A2

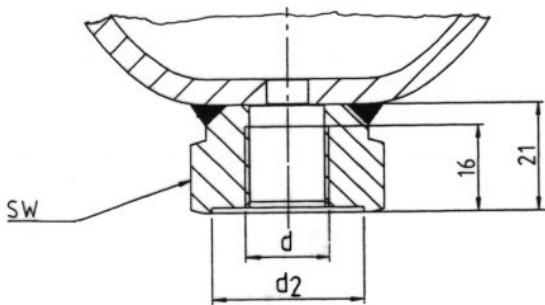

Shape B1

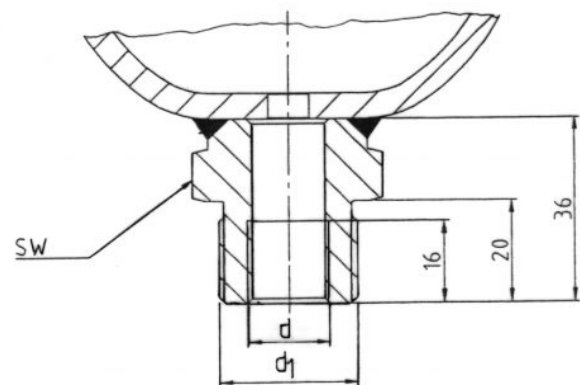

Technical Data Diaphragm accumulator – standard steel

0,075 – 3,5 litres / 80 – 350 bar

Diaphragm Accumulator Standard Steel Type	nominal volume litres	operating pressure P (bar)	perm. pressure ratio P2 : P0	mass kg	volume flow Q (l/min)	L mm	Ø D mm	Ø d1 mm	Ø d Zoll	Ø d2 mm	SW mm	connec-tion form
MS 0,075	0,075	250	8 : 1	0,7	35	90	64		G 1/2	29	32	A2
MS 0,16	0,16	250	8 : 1	0,9	35	101	74		G 1/2	29	32	A2
MS 0,25	0,25	210	8 : 1	1,1	35	107	84		G 1/2	29	32	A2
MS 0,32	0,32	210	8 : 1	1,3	80	116	93		G 1/2	29	32	A2
MS 0,32	0,32	330	8 : 1	1,6	80	118	95		G 1/2	29	32	A2

Diaphragm Accumulator Standard Steel Type	nominal volume litres	operating pressure P (bar)	perm. pressure ratio P2 : P0	mass kg	volume flow Q (l/min)	L mm	Ø D mm	Ø d1 mm	Ø d Zoll	Ø d2 mm	SW mm	connection form
MS 0,50	0,5	210	8 : 1	1,8	80	128	105	M33x1,5	G 1/2	29	41	B1
MS 0,50	0,5	330	8 : 1	2,4	80	136	110	M33x1,5	G 1/2	34	41	B1
MS 0,60	0,6	330	4 : 1	2,7	80	148	110	M33x1,5	G 1/2	34	41	B1
MS 0,75	0,75	150	8 : 1	2,1	80	140	117	M33x1,5	G 1/2	34	41	B1
MS 0,75	0,75	210	8 : 1	2,8	80	144	121	M33x1,5	G 1/2	34	41	B1
MS 0,75	0,75	330	8 : 1	3,5	80	148	125	M33x1,5	G 1/2	34	41	B1
MS 1,00	1,0	210	8 : 1	3,6	80	155	136	M33x1,5	G 1/2	34	41	B1
MS 1,00	1,0	250	8 : 1	3,6	80	155	136	M33x1,5	G 1/2	34	41	B1
MS 1,00	1,0	330	4 : 1	4,2	80	175	125	M33x1,5	G 1/2	34	41	B1
MS 1,40	1,4	140	8 : 1	5,2	80	178	150	M33x1,5	G 1/2	34	41	B1
MS 1,40	1,4	210	8 : 1	5,2	80	178	150	M33x1,5	G 1/2	34	41	B1
MS 1,40	1,4	250	8 : 1	5,2	80	178	150	M33x1,5	G 1/2	34	41	B1
MS 1,40	1,4	350	8 : 1	7,5	80	176	156	M33x1,5	G 1/2	34	41	B1
MS 2,00	2,0	100	8 : 1	5,5	140	192	163	M33x1,5	G 1/2	34	41	B1
MS 2,00	2,0	210	8 : 1	6,6	140	196	166	M33x1,5	G 1/2	34	41	B1
MS 2,00	2,0	250	8 : 1	7,5	140	200	170	M33x1,5	G 1/2	34	41	B1
MS 2,20	2,2	80	8 : 1	5,7	140	208	163	M33x1,5	G 1/2	34	41	B1
MS 2,80	2,8	210	4 : 1	8,2	140	248	166	M33x1,5	G 1/2	34	41	B1
MS 2,80	2,8	250	4 : 1	10,0	140	248	170	M45x1,5	G 3/4	44	46	B1
MS 3,50	3,5	250	4 : 1	11,6	140	285	170	M45x1,5	G 3/4	44	46	B1
MS 3,50	3,5	350	4 : 1	18,0	140	295	180	M45x1,5	G 3/4	44	46	B1

Technical Data Diaphragm accumulator – stainless steel

0,075 – 4,0 litres / 100 – 210 bar

Diaphragm Accumulator Stainless Steel Type	nominal volume ltr.	operating pressure P (bar)	perm. pressure ration P2 : P0	mass kg	volume flow Q (l/min)	L mm	Ø D mm	Ø d1 mm	Ø d Zoll	Ø d2 mm	SW mm	connection form
MS 0,075	0,075	200	8 : 1	0,7	35	90	64		G ½	29	32	A2
MS 0,16	0,16	180	8 : 1	0,9	35	101	74		G ½	29	32	A2
MS 0,25	0,25	160	8 : 1	1,1	35	107	84		G ½	29	32	A2
MS 0,32	0,32	160	8 : 1	1,3	80	116	93		G ½	29	32	A2
MS 0,50	0,5	150	8 : 1	1,7	80	130	105	M33x1,5	G ½	29	41	B1
MS 0,75	0,75	140	8 : 1	2,8	80	144	121	M33x1,5	G ½	34	41	B1
MS 0,75	0,75	210	8 : 1	3,5	80	148	125	M33x1,5	G ½	34	41	B1
MS 1,00	1,0	150	8 : 1	3,6	80	171	121	M33x1,5	G ½	34	41	B1
MS 1,40	1,4	150	8 : 1	5,2	80	178	150	M33x1,5	G ½	34	41	B1
MS 2,00	2,0	100	8 : 1	5,5	140	192	163	M33x1,5	G ½	34	41	B1
MS 2,80	2,8	100	4 : 1	6,0	140	244	163	M33x1,5	G ½	34	41	B1
MS 4,00	4,0	100	4 : 1	7,5	140	377	163	M45x1,5	G ½	46	46	B1

Characteristics

Installation position: as desired

Permissible operating temperature: -10°C bis +80°C (other temperatures on request)

Charging gas: Use nitrogen only! Oxygen or compressed air means danger of explosion!

Fluids: hydraulic oil (other fluids on request)

Instructions for mounting, maintenance and repair

According to the provided operating conditions the diaphragm accumulators should be charged at the charging pressure required in the place of installation.

When charging gas use nitrogen only! Oxygen means danger of explosion.

The diaphragm accumulators can be screwed directly on the piping. When using a fluid connection with external thread, the accumulator can be fastened in threaded holes. In case of strong vibrations the accumulator should be protected against loosening. For this we recommend the HST-clamp straps. In the vicinity of the diaphragm accumulator a discharge and shut-off valve and a safetyvalve against excess pressure have to be provided in the hydraulic system. The maintenance of the accumulator is limited to the control of the gas pressure necessary for the respective function. Furthermore, we recommend to check the tight fit of the fastening of the accumulator and the pipe connections. Repair and restoring work of the accumulator are strictly prohibited, neither mechanical machining nor welding, soldering or other heat treatment.